



features

- Immediate cut-off of excessive heat
- No generation of heat
- UL94V-0 epoxy case
- Suitable for flow and reflow soldering
- UL 198G approved, file #131375
- One-time fuse device
- Marking: Black body color with yellow marking

circuit protection

dimensions and construction

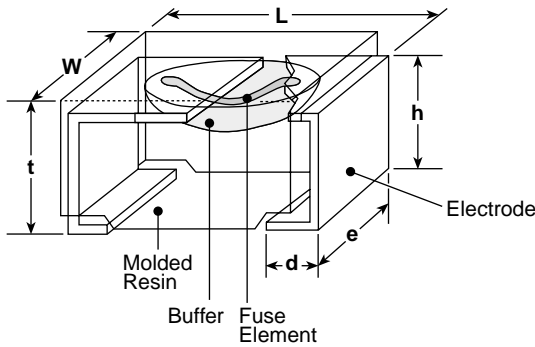

Size Code	Dimensions inches (mm)					
	L	W	t	h	e	d
2B	.126±.008 (3.2±0.2)	.063±.008 (1.6±0.2)	.047±.008 (1.2±0.2)	.031±.004 (0.8±0.1)	.047±.004 (1.2±0.1)	.024±.004 (0.6±0.1)
2E		.098±.008 (2.5±0.2)	.087±.008 (2.2±0.2)	.075±.004 (1.9±0.1)	.067±.004 (1.7±0.1)	.02±.004 (0.5±0.1)

ordering information

Old Part #	CCP	2E	20		T
	Type	Size	Rating		Packaging
New Part #	CCP	2B	20	T	TE
	Type	Size Code	Rating	Termination Material	Packaging
		2B: 1206 2E: 1210	Reference rating chart	T: Sn	TE: 7" embossed plastic (2B - 3,000 pieces/reel) (2E - 2,000 pieces/reel)

For further information on packaging, please refer to Appendix A.

Specifications given herein may be changed at any time without prior notice. Please confirm technical specifications before you order and/or use.

applications and ratings

Part Designation	Current Rating	Fusing Current	Fusing Time	Internal R. Maximum (mΩ)	Maximum Open Circuit Voltage	Rated Ambient Temperature	Operating Temperature Range	
CCP2B15	0.75A	1.5A	1 second max. @ fusing current	150	24V	+70°C	-40°C to +125°C	
CCP2B20	1.00A	2.0A		100				
CCP2B25	1.25A	2.5A		75				
CCP2B30	1.50A	3.0A		60				
CCP2B35	1.75A	3.5A		50				
CCP2B40	2.00A	4.0A		45				
CCP2B50	2.50A	5.0A		35				
CCP2B63	3.15A	6.3A		23				
CCP2E10	0.4A	1.0A		200				72V
CCP2E13	0.52A	1.3A		170				
CCP2E15	0.6A	1.5A		150				
CCP2E20	0.8A	2.0A		100				
CCP2E25	1.0A	2.5A		75				
CCP2E30	1.2A	3.0A		60				
CCP2E35	1.4A	3.5A		50				
CCP2E38	1.5A	3.8A		48				
CCP2E40	1.6A	4.0A		45				
CCP2E45	1.8A	4.5A		40				
CCP2E50	2.0A	5.0A		35				
CCP2E63	2.5A	6.25A		23				

circuit protection

environmental applications

Derating Curve

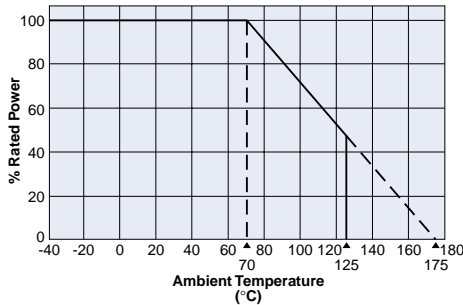

Fusing Characteristics

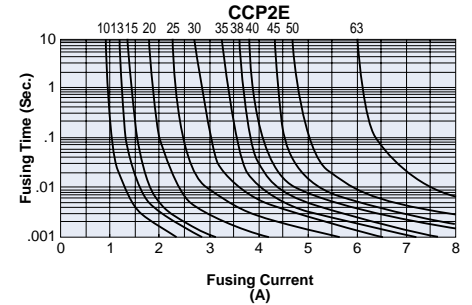
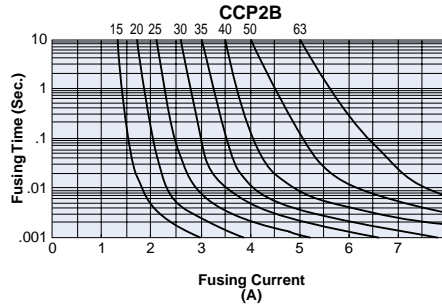

Performance Characteristics

Parameter	Requirement	Test Method
Clearing Time	Within 1 second	CCP2E, CCP2B: 250% of rated current shall be carried
Open Circuit Voltage	No fusing, flaming, explosion	Apply DC voltage between the termination after fusing CCP2B: 24V, CCP2E: 72V
Residual Resistance	Over 10kΩ	Measuring DC resistance after fusing
Bending Test	No breakdown of termination and disconnection	Holding point: 90mm, Bending: 10mm, 1 time
Resistance to Solder Heat	ΔR: ±10%	260°C ± 5°C, 0.5 seconds, 2 cycles
Solderability	95% coverage minimum	230°C ± 5°C, 3 seconds ± 0.5 seconds
Load Life	ΔR: ±10%	70°C ± 3°C, 1000 hours, rated current
Moisture Resistance	ΔR: ±10%	40°C ± 2°C, 90% RH, rated current
Temperature Cycling	ΔR: ±10%	-40°C (30 minutes)/+125°C (30 minutes), 10 cycles
Resistance to Solvent	No aberration of marking in appearance	Conforming to MIL-STD-202F

Specifications given herein may be changed at any time without prior notice. Please confirm technical specifications before you order and/or use.