

SLAMTEC Aurora S

Compact AI-Integrated Spatial Perception System

User Manual

- More Stable
- More Accurate
- More Powerful



Contents

Introduction	4
System Components	5
Technical Specifications	6
Interface Parameters	7
Body Coordinate Origin.....	8
Mechanical Dimension.....	9
Product List	9
Ethernet	10
Mapping	10
1. Preparation	10
2. Aurora Boots	10
3. Aurora Initialization	11
4. Mapping	12
5. Save the map.....	13
Aurora Remote.....	14
1. Main Interface :	14
2. View Switching.....	14
3. Camera view.....	15
4. IMU view	15
5. Photo-Real Dense Mapping.....	16
ROS Development Kit.....	19
Firmware upgrade.....	20
Notes.....	22
Revision history.....	23

Introduction

The Slamtec Aurora S is SLAMTEC's new-generation compact AI-powered integrated spatial perception system, combining visual perception, inertial measurement unit (IMU), and SLAMTEC's proprietary deep learning vSLAM technology. With a highly integrated, plug-and-play design, it enables high-precision 3D mapping, perception, and spatial localization across diverse indoor and outdoor scenarios. It is widely applicable to fields such as embodied intelligence, industrial automation, digital twins, and low-speed autonomous driving.



Core Functions

- **SLAMTEC AI Deep Learning Engine**
- **Indoor and Outdoor Real-Time 3D Mapping and Localization**
- **6DOF Spatial Positioning:** Provides high-precision real-time position and pose information
- **End-to-end Stereo Depth Estimation:** Real-time generation of dense depth data
- **AI Object Recognition and Segmentation:** Real-time generation of object segmentation maps
- **Expandable LiDAR:** Provides higher-precision 2D mapping

Supporting Software and Development Support

- **Aurora Remote UI:** Visualization software that enables easy scenario reproduction and digital twin applications

- **Aurora Remote SDK:** Comprehensive SDK supporting C++, ROS1/ROS2, and Python for rapid secondary development, enabling customized applications and accelerating downstream product deployment

Feature Overview

- AI Deep Learning vSLAM Engine
- Integrated design with compact size
- Plug-and-play with no external dependencies Universal indoor/outdoor compatibility with strong environmental adaptability

System Components

The SLAMTEC Aurora S integrates dual fisheye cameras, an IMU, an LiDAR (optional), and an onboard processing board into a compact system. It provides real-time 3D point cloud maps, 6DOF spatial positioning, dense depth maps, and object segmentation outputs. With the Aurora Remote SDK, developers can access reliable real-time data to accelerate the development of applications such as dense mapping, scene reconstruction, semantic mapping, path planning and navigation, and 3DGS. The Aurora Remote UI software supports product evaluation and scene reproduction with interactive visualization.

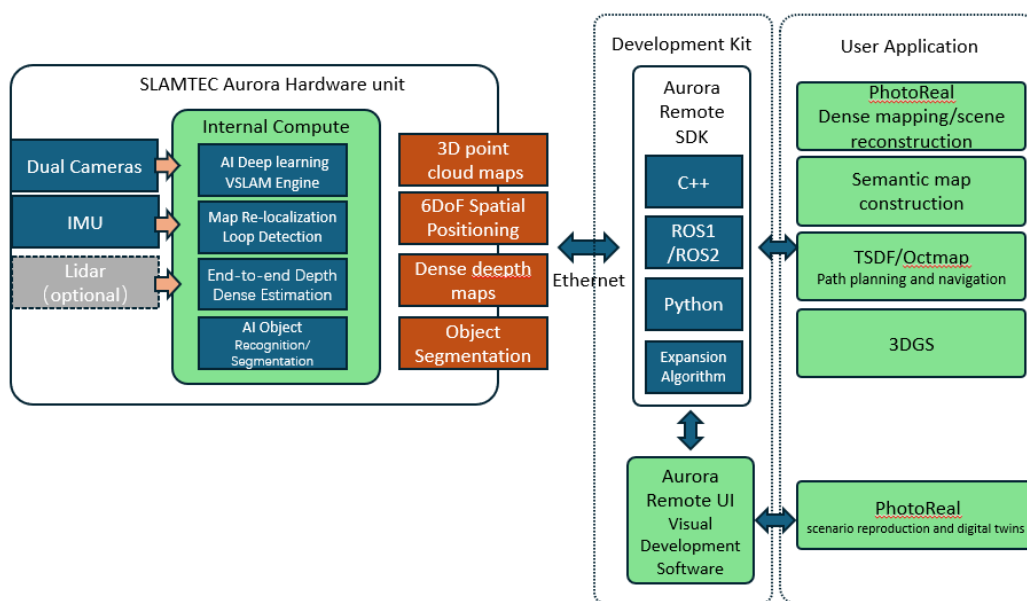

Technical Specifications

Core parameters		Specific indicators
Maximum Mapping Area		>1,000,000 m ²
Relocation		Global relocation is supported, with an accuracy \pm 5cm
Map Management		Supports incremental mapping, map loading and saving
Mapping and Localization mode		Primarily based on deep learning vSLAM, with optional LiDAR fusion
Multi-sensor Synchronization Mechanism		Hardware time synchronization
Camera Specifications		Binocular fisheye, 60mm Baseline, FOV 180°, Global Shutter, RGB
Camera Frame Rate		Typical 15Hz, 10/30Hz can be customized
Dense Depth Camera Function		End-to-end deep learning, robust under strong light and weak texture; >90% detection rate
AI Object Recognition and Segmentation		Supports 18 outdoor scenes and 80 indoor scenes; customizable expansion available
Maximum Tilt Angle	Optional lidar	No requirement without LiDAR; for better 2D mapping, recommended $\leq 30^\circ$
2D Map Resolution		2cm/5cm/10cm adjustable
LiDAR Measures Range		Up to 40m @ 70% reflectivity
Power Consumption		10W (typical, LiDAR not included)
Operating Temperature		-20°C~50°C
Starting Temperature		$\geq 0^\circ\text{C}$
Storage Temperature		-20°C~60°C

Interface Parameters

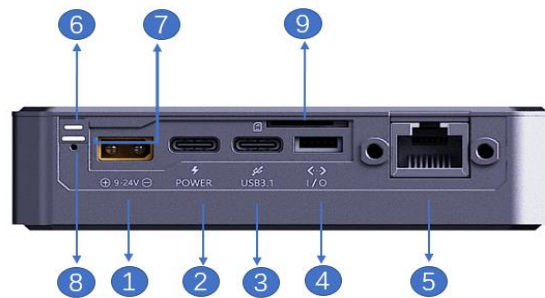

NO.	category	specification	Parameters/descriptions
1	Power Input	XT30PW-M	DC 9-24V
2	Power Input	USB Type-C	Supports USB PD3.0 protocol power input
3	Extension Interface	USB 3.1 Gen1	Supports OTG mode, compatible with Device/Host;
4	I/O Interface	SH1.0-6PWB	6Pin peripheral expansion interface for LiDAR connectivity
5	Data Interface	Ethernet RJ-45	Supports Gigabit Ethernet (1000BASE-T), full-duplex communication; Default IP: 192.168.11.1
6	Run Indicator	White LEDs	Indicates device operating status
7	Status Indicator	Red/green two-color LEDs	Indicates device status
8	Reset Button	-	Press and hold while powering on for 30 seconds to clear configuration; device restarts automatically after reset
9	Storage Expansion	TF card slot	Supports TF card extension for log storage

Status Indicator Description

Indicator status	illustrate
White Light Steady On	System running
Green Flashing	Boot complete, awaiting initialization
Green Light Steady On	Initialization complete, mapping started
Red Light Steady On	Device error

Body Coordinate Origin

The position calculated by the SLAM system corresponds to the world coordinates of the device's body coordinate origin. The precise definition of this origin is detailed in the mechanical dimensions diagram.

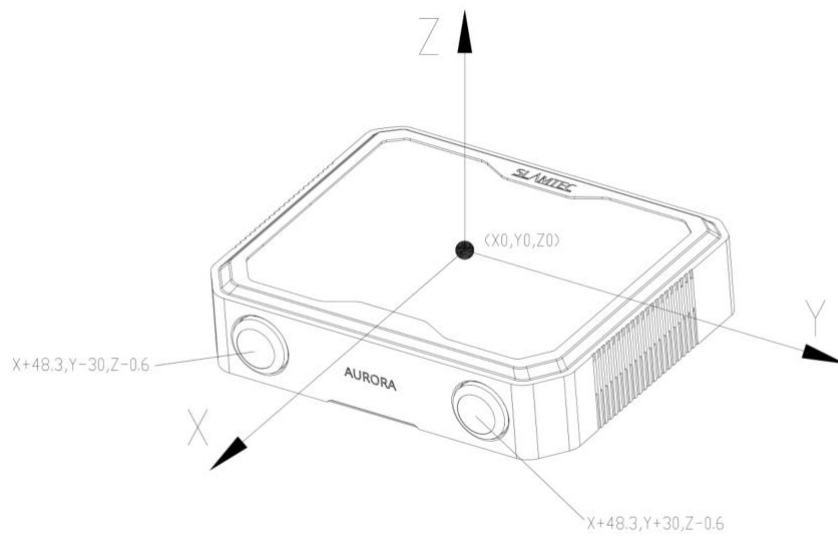

Mechanical Dimension

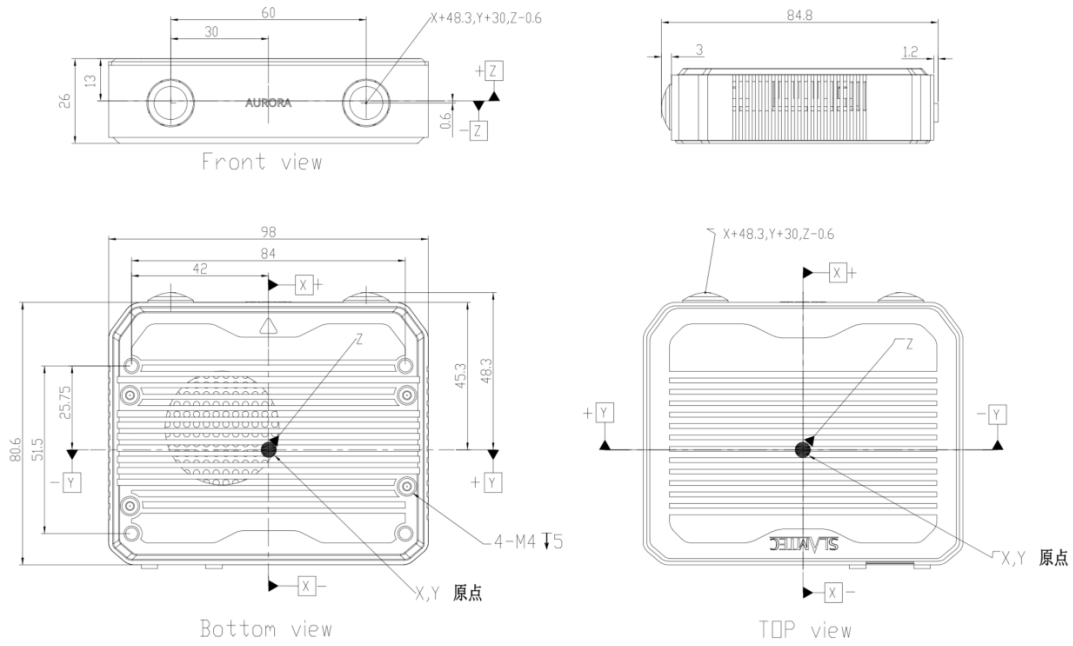

Product List



Name	Quantity	Notes
Aurora S A2M2	1	Standard
Power Adapter	1	Standard
Accessory Kit	1	Optional (at additional cost), including: Tripod extension legs ,Bracket (with screw), AC650 driver-free USB Wi-Fi adapter, USB OTG adapter

--	--	--

Ethernet

The default configuration mode for Aurora Ethernet is static IP mode with an IP address of 192.168.11.1. The computer is connected to Ethernet, and 192.168.11.1 is accessed through a browser to obtain Aurora device information and simple configuration of Aurora.

Mapping

1. Preparation

Prepare a laptop and install [the Aurora Remote](#).

<https://www.slamtec.com/cn/Support#aurora>

2. Aurora Boots

Connect the device to a DC 9-24V 2A power supply to turn it on or power the device via USB3.0 power supply protocol Connect to Aurora

Connect the computer to the Aurora device via Ethernet or Wi-Fi hotspot (SSID:SLAMWARE-Aurora-xxxxxx) ,this method can only be used with the accessory kit.

Launch Aurora Remote, enter the IP address "192.168.11.1" in the "Manually enter address" field in the pop-up window, and then click "Connect"

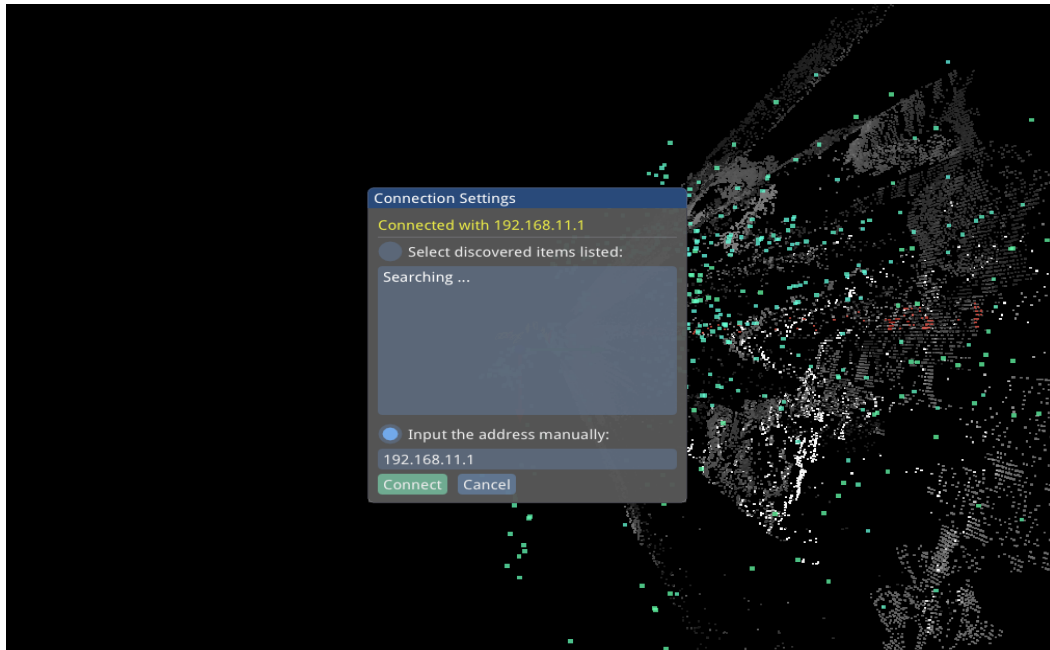

Upon successful connection, the Mapping interface will be displayed.

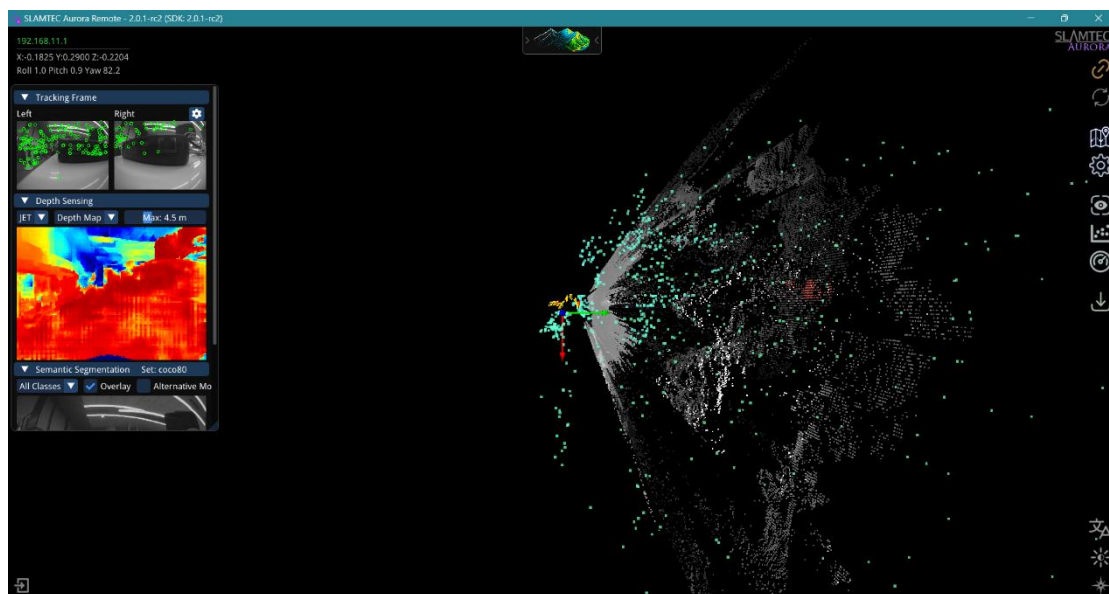

3. Aurora Initialization

- Position Aurora in a feature-rich environment within 2 meters. Avoid open areas , highly reflective surfaces (e.g., large areas of glass), and dynamic environments to ensure sufficient initialization.
- Keep the device at rest.
- Click on the Aurora Remote main interface "Device Operations" -> "Reset Map". The device starts initializing.

- Upon initialization is complete, a pop-up window will pop up in the lower right corner of the Aurora Remote, indicating that the initialization is complete.

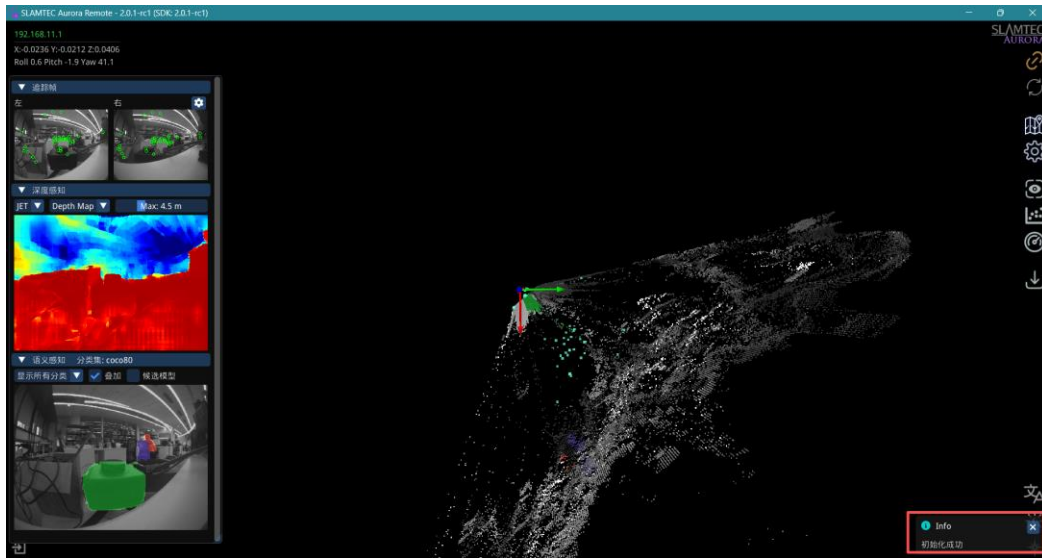

4. Mapping

- Route planning and suggestions
 - ✧ Ensure the scanning path covers diverse features.
 - ✧ Avoid continuously scanning new areas; include loop closures where possible.
 - ✧ Avoid the effects of dynamic objects as much as possible.
 - ✧ Prioritize closed-loop paths to improve map consistency.
 - ✧ Avoid unnecessary overlapping in already closed-loop areas to conserve memory.
- Mapping Guidelines:
 - ✧ Clear the existing map before creating a new one to ensure optimal performance of the Mapping Optimization Engine.
 - ✧ Keep the device level; avoid tilting beyond 20°.
 - ✧ Maintain stable movement; avoid sudden stops or jerky motions, as these may affect accuracy.
 - ✧ After completing a loop, continue moving briefly to reinforce map alignment.
 - ✧ If a loop does not close, continue mapping until closure is achieved.
 - ✧ Move at normal walking speed; reduce speed in feature-rich areas, narrow spaces, and turns.

- ✧ For multi-room or multi-floor environments:
 - Ensure all doors are open before scanning.
 - Pause and scan sideways when passing through doorways to capture features on both sides.
 - If a door is closed, turn slowly to face away from the door, open it, and enter gradually.
 - When exiting confined spaces, ensure sufficient features and structural details are visible. Avoid rapid perspective changes.

5. Save the map

From the Aurora Remote main interface, select Map Manager → Download to File to save the map in STCM format.

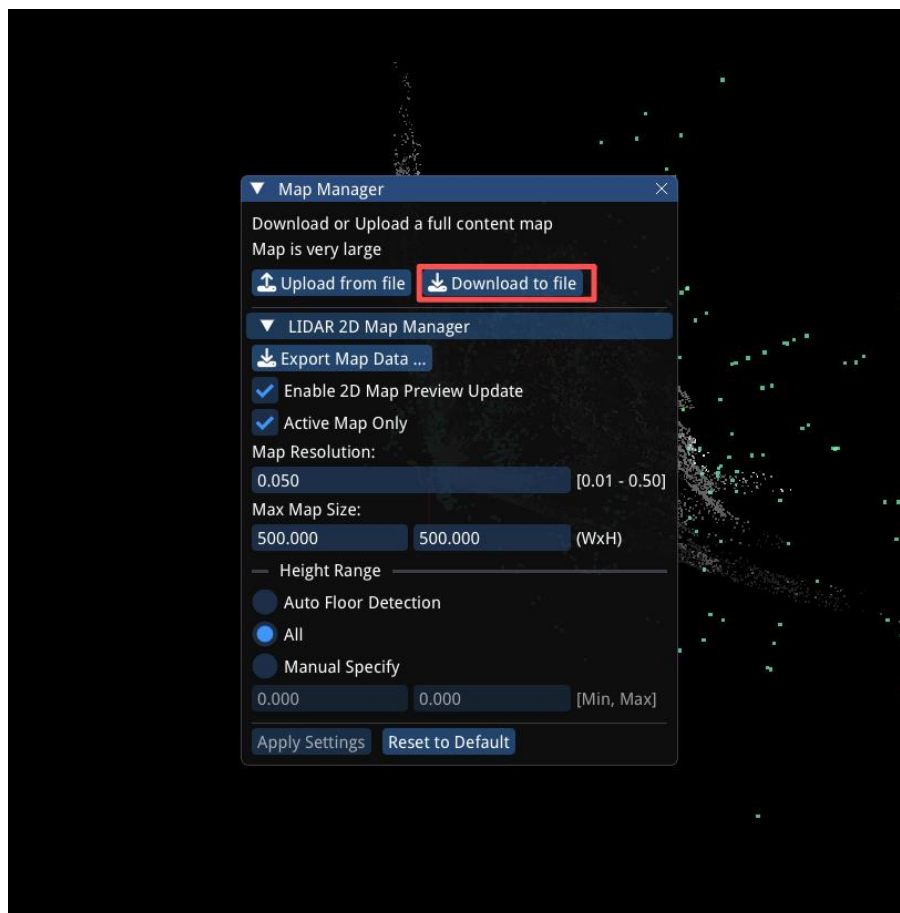

Aurora Remote

1. Main Interface :

Use the language switch option to select the preferred language

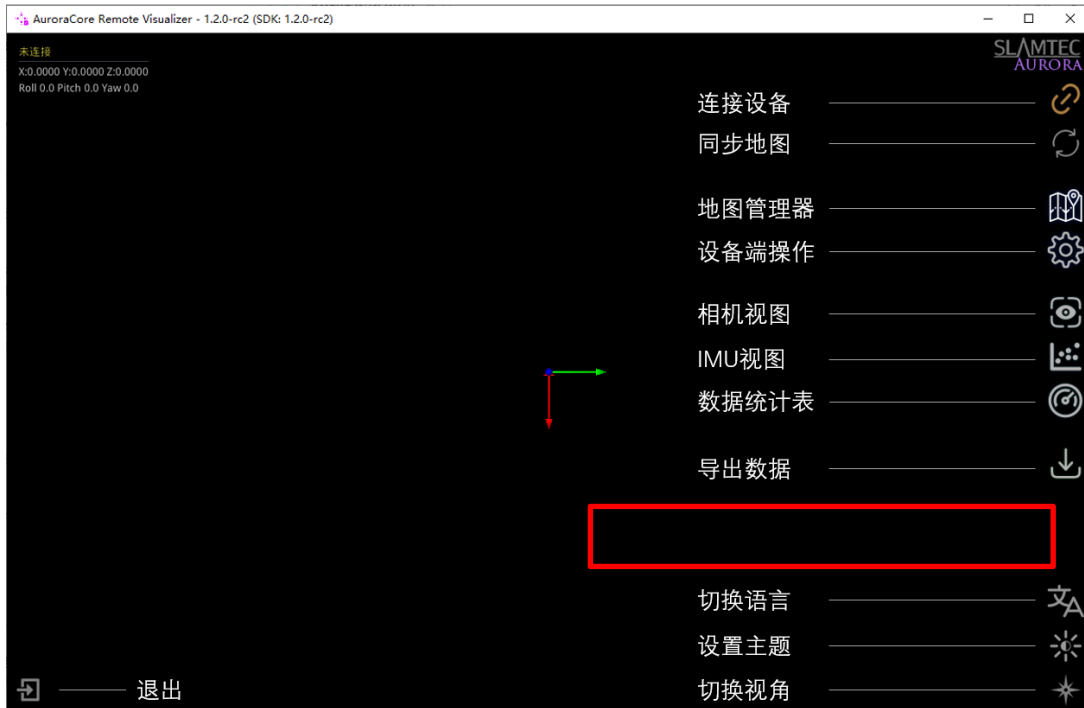

2. View Switching

Toggle between different viewing perspectives by clicking the "Switch View" button.

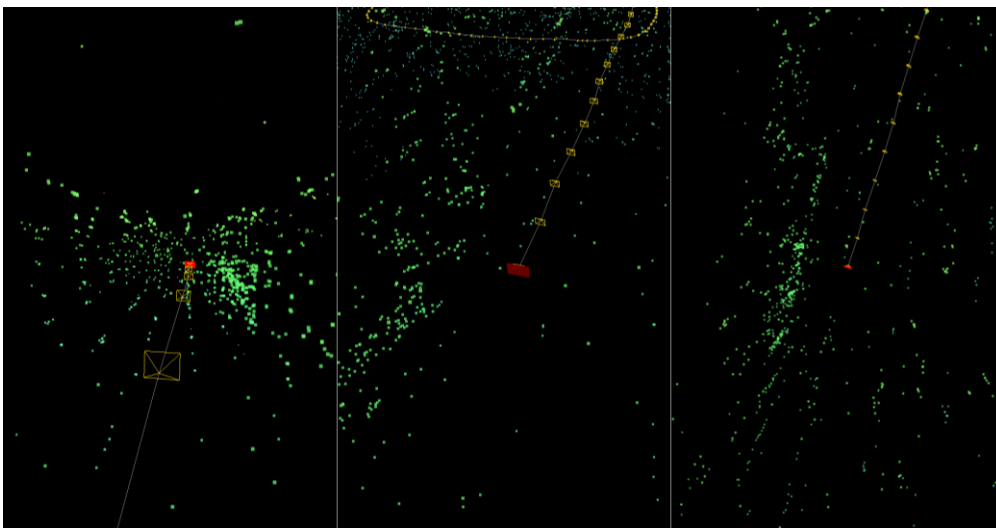

3. Camera view

Click the "Camera View" icon to access real-time previews of the camera feed, depth camera frame, and semantic perception display.

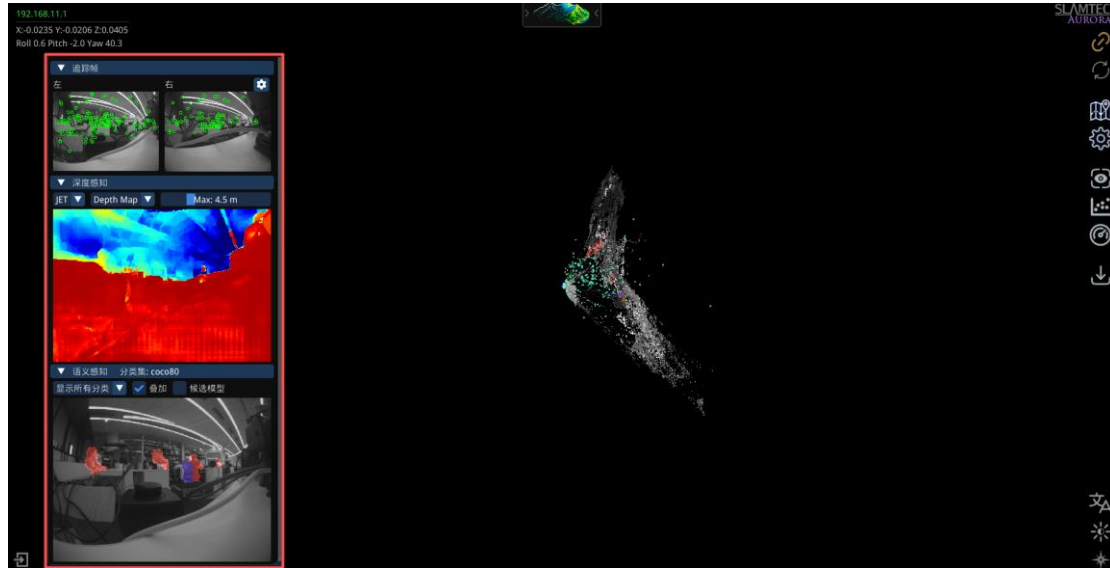

4. IMU view

Click the "IMU View" icon on the main interface to monitor real-time gyroscope and accelerometer data in real time.

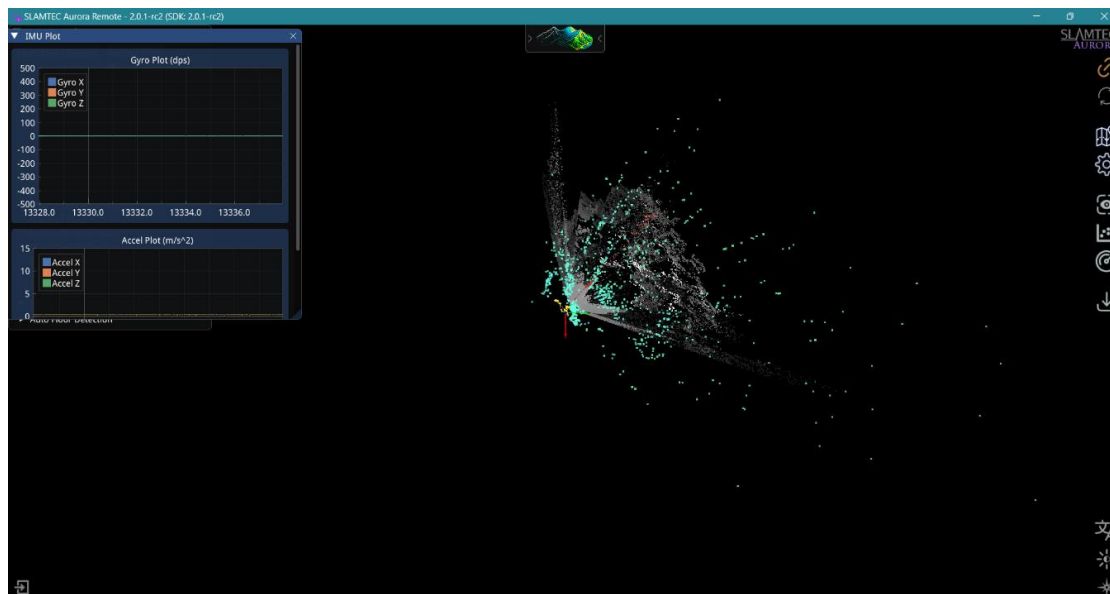

5. Photo-Real Dense Mapping

Open Photo-Real Dense Mapping → Select Folder... and choose the dataset storage directory

- Start Collecting and Mapping
 - ✧ Select Start Collection and Mapping, then choose Finish to download the dataset.
 - ✧ Select Start Densification to process the dense point cloud dataset.

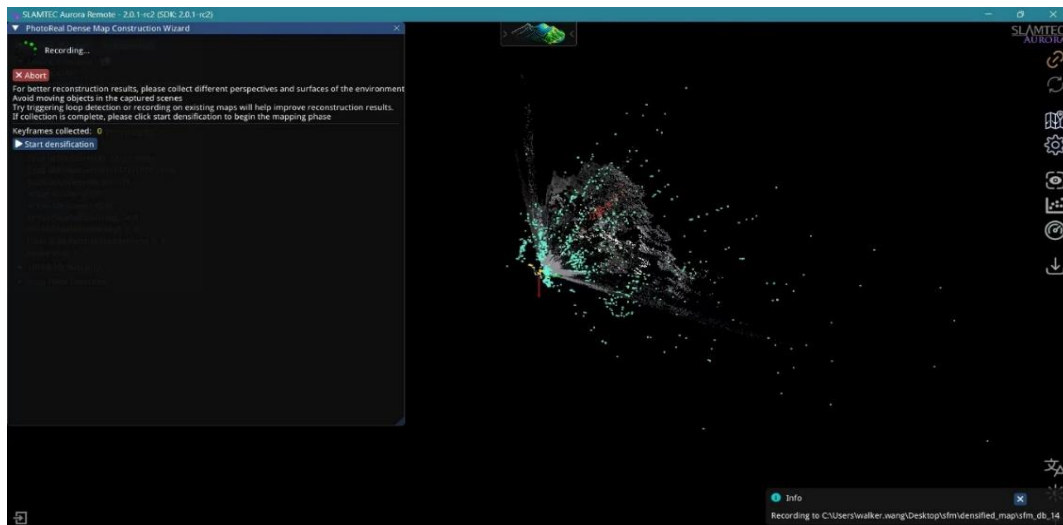

- Load the recorded SfM dataset
 - ✧ Click Load Recorded SfM Dataset Map and select the corresponding folder.
 - ✧ Monitor the upload progress until completion.

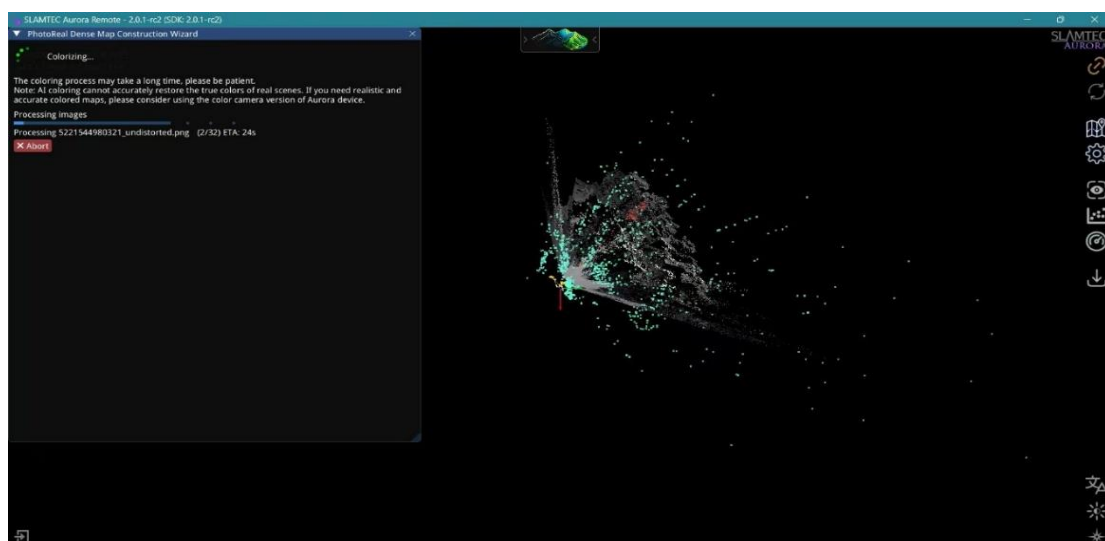

- Map Navigation
 - ✧ Use the mouse wheel to zoom in/out.

- ✧ Click and drag with the right mouse button to pan the map.
- ✧ Click and drag with the left mouse button to rotate the map.
- Resetting the Map
 - ✧ To clear the current map and reinitialize the device, navigate to Device Operations → Reset Map
- Syncing the Map
 - ✧ The "Sync Map" button updates the interface with all background map changes. Full map updates occur automatically upon loop closure detection.
- Saving/uploading Maps
 - ✧ Save Map: Go to Map Manager → Download to File to export the map in STCM format.

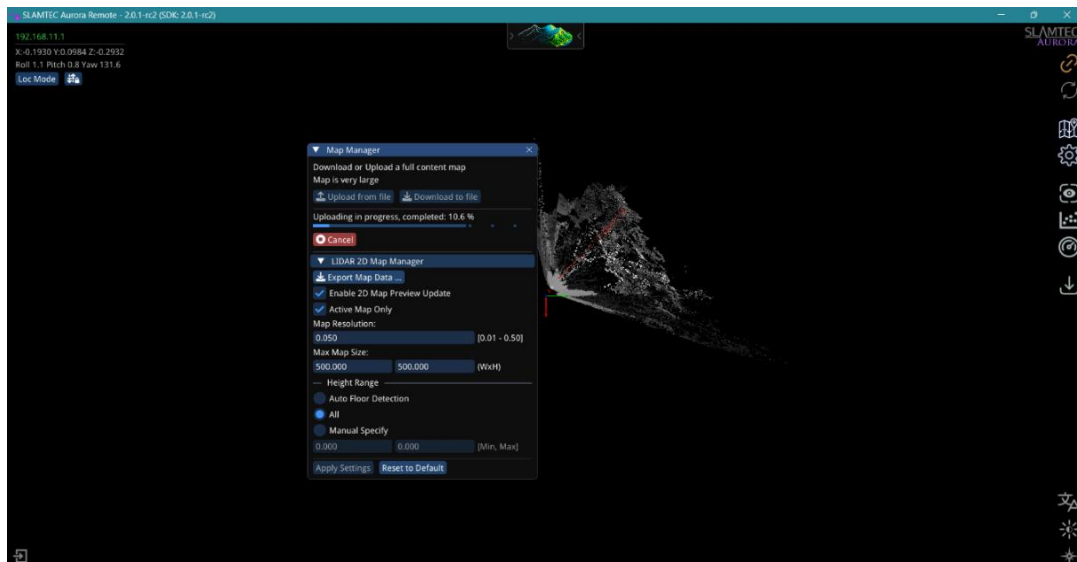

- ✧ Upload Map: Select Upload from File, choose the map file, and monitor the upload progress. A success notification will appear upon completion.

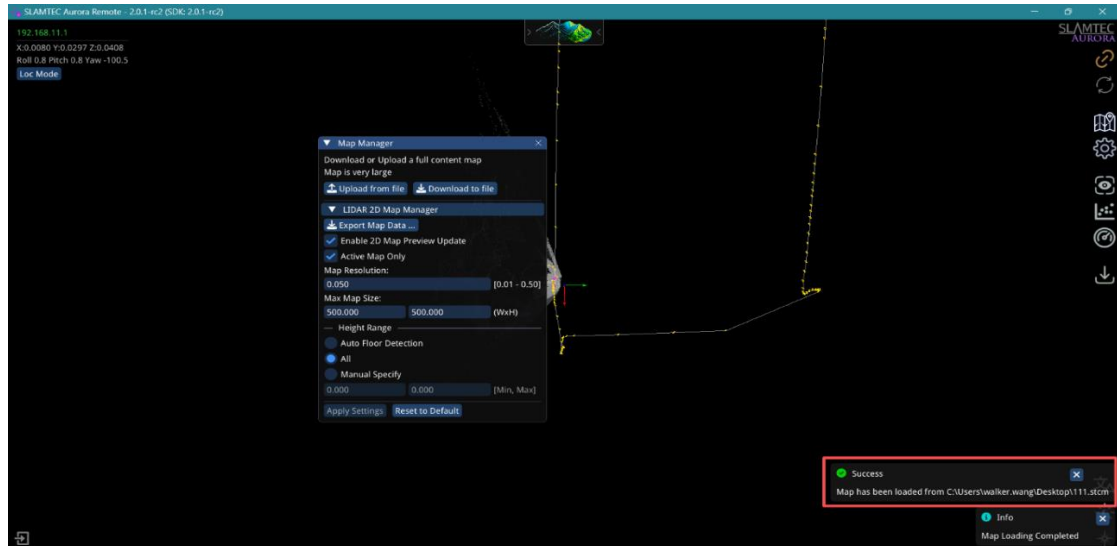

6. Notification Messages

The following notifications may appear during operation:

Message	Description
Initialization succeeded	Device initialized successfully; mapping can begin
Initialization failed	Device initialization failed; mapping unavailable
Map optimization completed	Loop closure detected and successfully optimized
Track loss	No feature points detected in the camera frame.
Track loss recovery	Feature point re-detected
Map loading starts	Map loading initiated
The map is loaded	Map loading completed
Map saving starts	Map saving initiated
The map was saved	Map saving completed

ROS Development Kit

1. Official Website Address

Download Path: https://github.com/Slamtec/aurora_ros

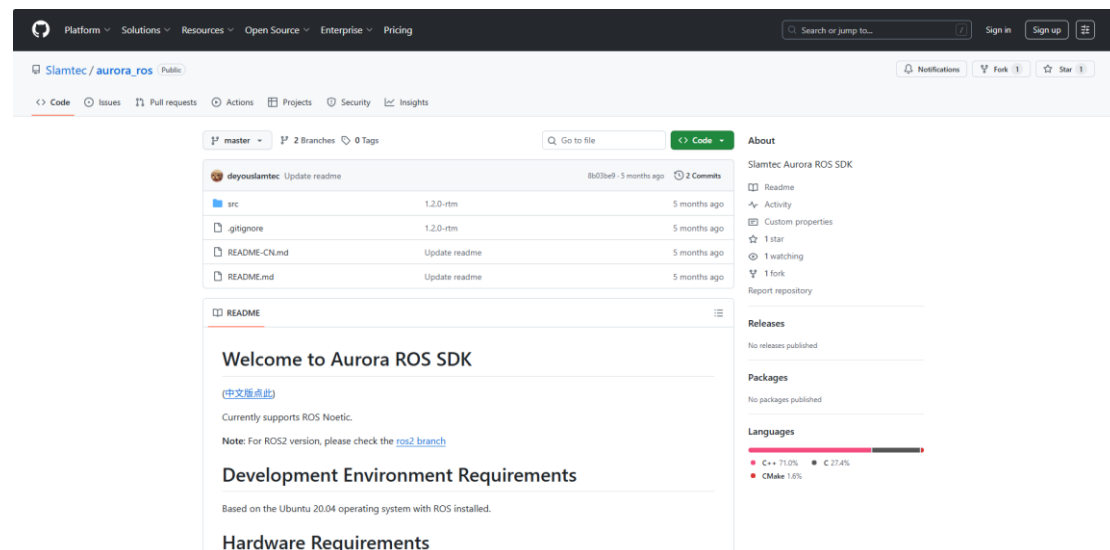

2. Readme Acquisition Address

https://github.com/Slamtec/aurora_ros/blob/master/README-CN.md

3. Development Environment

Ubuntu 20.04 operating system with ROS installed.

4. Hardware Requirements

A powered-on Aurora device with a valid IP configuration.

The slamware_ros_sdk_server_node will attempt to connect to this device upon startup.

5. User Guide

- **Download the Source Code**

```
git clone https://github.com/Slamtec/aurora_ros
```

- **Compilation**

```
cd aurora_ros
source /opt/ros/noetic/setup.bash
catkin_make
```

- **Launch the Node**

If using AP mode, connect to its hotspot first.

- **Execute the following command to launch the node**

```
source devel/setup.bash
roslaunch slamware_ros_sdk slamware_ros_sdk_server_and_view.launch
ip_address:=192.168.11.1
```

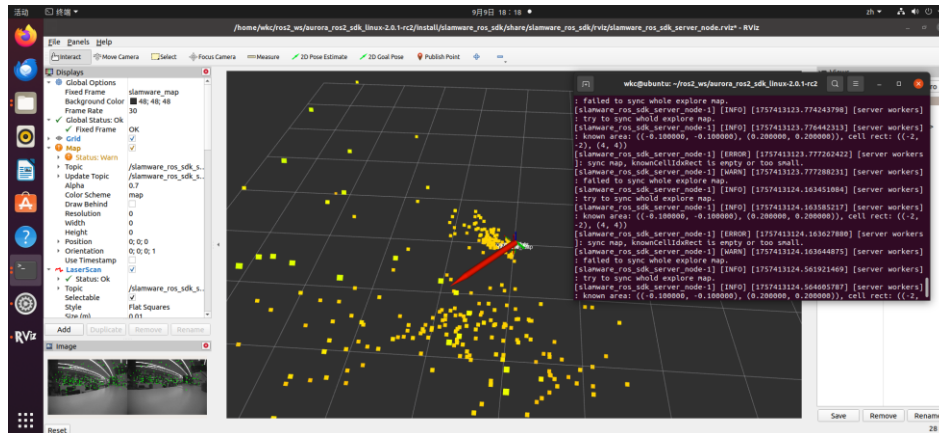

- Refer to the Wiki for detailed node documentation.

https://developer.slamtec.com/docs/slamware/aurora-ros2-sdk/slamware_ros_sdk_server_node/

Firmware upgrade

1. Power on the Aurora device.
2. Connect the computer to the Aurora Ethernet port.
3. Access <http://192.168.11.1> via a web browser.

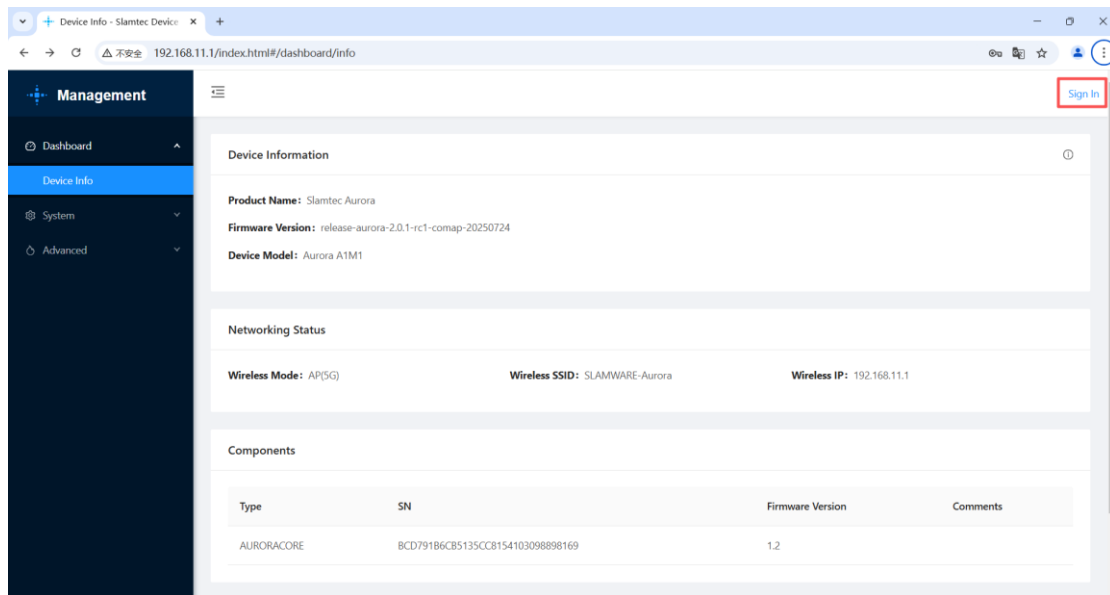

4. Click Sign in and enter the credentials:

Username: admin

Password: admin111

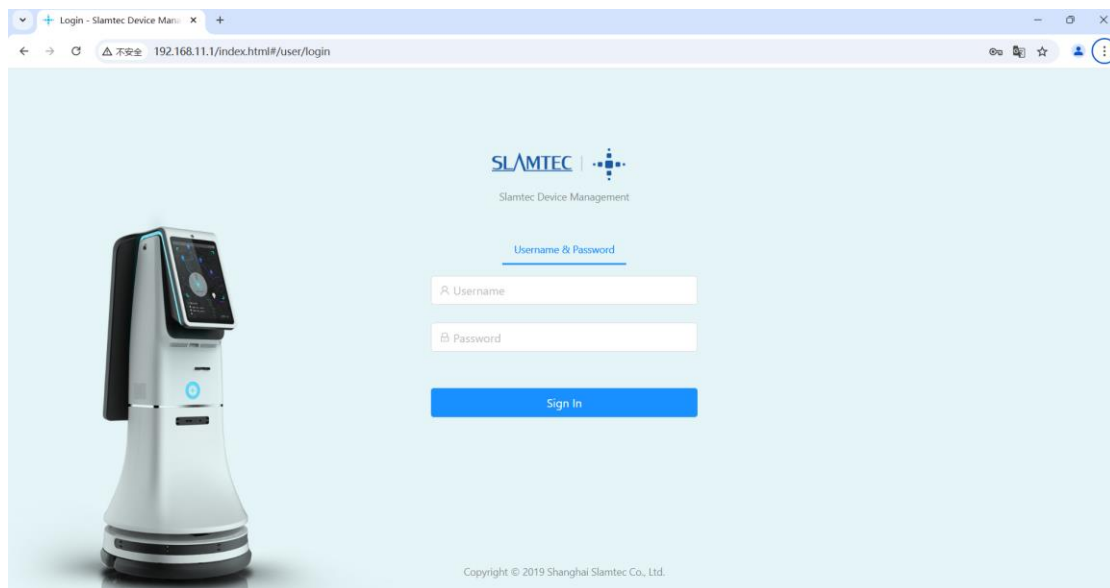

5. Navigate to System → Firmware Update → Choose File and select the firmware file.

6. Click Start Firmware Update.

7. Wait for the "success" message in the upgrade log indicating completion.

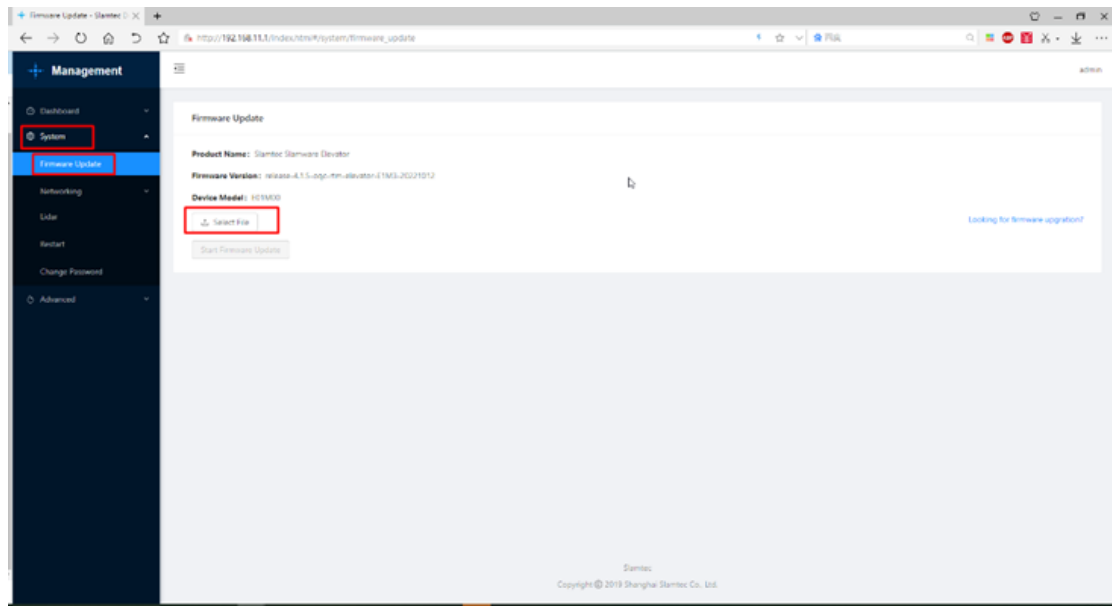

Notes

1. Avoid impacts, drops, or vibrations to prevent device damage.
2. Keep the lens clean; do not touch directly. Use a cleaning cloth for maintenance.
3. Ensure proper ventilation; do not block ventilation openings during operation.

Revision history

Date	Version	Description
2025-09-15	1.0	Initial Version
2025-10-13	1.1	add body coordinate origin