



주식회사 포트론

## PHOTRON 3W POWER LED

*3W High Power Light Emitting Diode For Application*

DEVICE : Red, Amber, Green (ES, ES), Blue (ES, ES), White (ES, ES), color

FORMING DATE. 2007년 06월 14일

CUSTOMER .

DESIGN	CHECK	APPROVAL

**PHOTRON CO. , LTD**

521-18 Yanggi-Ri, Gongdo-Eup,

Anseong-City, Kyungg-DO, korea

◆ Specification Contents

- POWER LED Series Feature

- Feature

- Application.

- High Power led Part Explanation

- Absolute maximum ratings

- Luminous Flux Characteristics

- Forward Voltage Characteristics

- Dominant Wavelength Characteristics

- Wavelength spectrum

- Forward Current & Ambient Temperature

- Typical Radiation Pattern

- Forward Current & Ambient Temperature

- Relative Luminous Flux & Forward Current

- Outline Dimensions

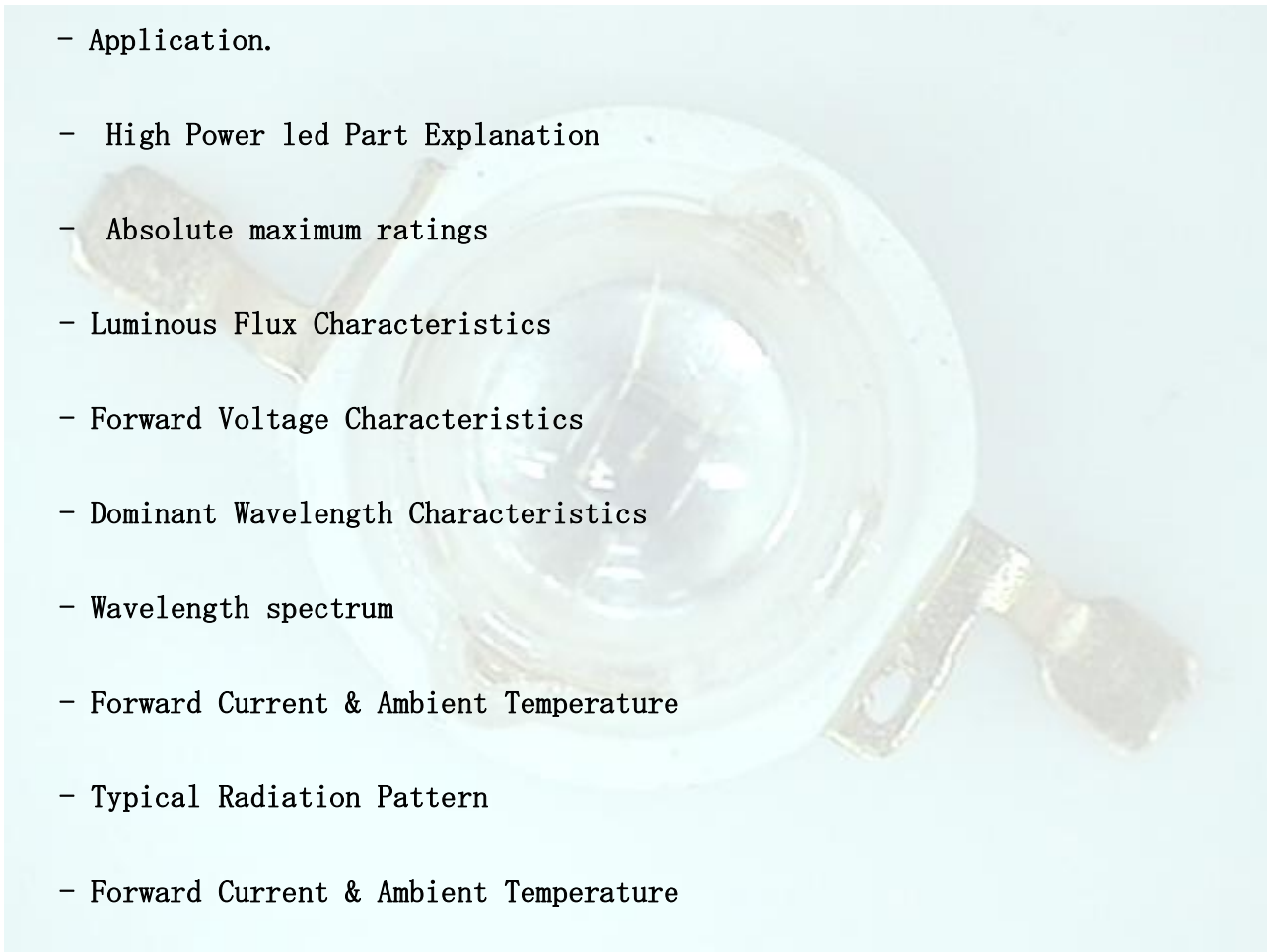

## 1. POWER LED Series Feature

High power LED is a revolutionary, energy efficient and compact new light source, combining the Lifetime and reliability advantages of Light Emitting Diodes with brightness of conventional lighting.

## 2. Feature

- ▷ Super high Flux output and Luminance
- ▷ High current operation
- ▷ Low forward voltage operation
- ▷ Superior Thermal Stability.
- ▷ ESD Class(Mil Std-883d Method 3017.7)based on Human Body Model (HBM):**Class1**
- ▷ ROHS Compliant

## 3. Application.

- ▷ Automotive Lighting System
- ▷ Outdoor / Indoor Lighting System
- ▷ Sign Board
- ▷ Architectural Lighting
- ▷ Projector Light source
- ▷ Traffic Signals
- ▷ LCD TV Backlight
- ▷ Monitor Backlight



4. High Power led Part Explanation

Full Part Code : P P ◇◇◇ - ◇ ◇ ◇ ◇ - ◇◇ ◇ ◇ ◇

① ② ③                    ④ ⑤ ⑥ ⑦                    ⑨ ⑩ ⑪ ⑫

(1) P - Photron initial

(2) P - Photron Power LED LAMP

(3) ◇◇◇ - Wavelength ( Dominant / peak)

- White led lamp code : 00W

(4) ◇ - Size of lens

(5) ◇ - Shape of lens

L: Lambertian, B: Batwing, S: Sid Emitting, I: Silicon Lens, T: Star Pcb

(6) ◇ - Viewing angle( $\phi$  1/2)

(7) ◇ - Power Dissipation

1W: 1, 3W: 3, 5W: 5

\* Internal Number

(9) ◇◇

(10) ◇

(11) ◇

(12) ◇

**5. Absolute maximum ratings.**

( Ta = 25°C )

Parameter	Symbol	Ratings	Unit
Forward current	I <sub>F</sub>	750	mA
Pulse Forward Current *1	I <sub>FP</sub>	1000	mA
Reverse voltage	V <sub>R</sub>	5	V
Power dissipation(blue, green, white)	P <sub>D</sub>	3.10	w
Power dissipation(red, yellow)	P <sub>D</sub>	2.40	w
LED junction Temperature(blue, green, white)	T <sub>j</sub>	136	°C
LED junction Temperature(red, yellow)	T <sub>j</sub>	128	°C
Viewing angle(Lamdertan Lens)	Θ <sub>1/2</sub>	125	deg
Operation temperature	Topr.	-30 ~ + 110	°C
Storage temperature	Tstg.	-40 ~ + 120	°C
Manual Soldering Time at 260°C (MAX.)	Tsol.	5	seconds

\*Notes

\*1 IFP Conditions : Pulse Width ≤10msec. And Duty Ration ≤1/10

\* ESD Class based on Human Body Model (HBM) : **Class1.**

\* Photron maintains a tolerance of ±10% on power measurements.

6. Luminous Flux Characteristics at 700mA, Ta = 25°C

Color	Part No	Item	Symbol	Luminous Flux			Unit
				MIN	TYP	MAX	
Red	PP625-8L63-AOA0BI	Luminous Flux	LX	25	45		lm
Amber	PP592-8L63-AOA0BI	Luminous Flux	LX	25	45		lm
Green	PP525-8L63-ESESBI	Luminous Flux	LX	32	55		lm
Blue	PP465-8L63-ESESBI	Luminous Flux	LX	12	28		lm
white	PP00W-8L63-ESESBI	Luminous Flux	LX	33	58		lm

\* Luminous Flux Measurement is ±10%.

7. Forward Voltage Characteristics at 700mA, Ta = 25°C

Color	Part No	Item	Symbol	Luminous Flux			Unit
				MIN	TYP	MAX	
Red	PP625-8L63-AOA0BI	Forward Voltage	Vf	1.8	2.25	3.2	V
Amber	PP592-8L63-AOA0BI	Forward Voltage	Vf	1.8	2.25	3.2	V
Green	PP525-8L63-ESESBI	Forward Voltage	Vf	2.7	3.5	4.2	V
Blue	PP465-8L63-ESESBI	Forward Voltage	Vf	2.7	3.5	4.2	V
white	PP00W-8L63-ESESBI	Forward Voltage	Vf	2.7	3.5	4.2	V

\* Forward Voltage Measurement allowance is ±3%.

8. Dominant Wavelength or Color Temperature Characteristics at 700mA, Ta = 25°C

Color	Part No	Item	Symbol	Luminous Flux			Unit
				MIN	TYP	MAX	
Red	PP625-8L63-AOA0BI	Dominant Wavelength	$\lambda d$	615		645	nm
Amber	PP592-8L63-AOA0BI	Dominant Wavelength	$\lambda d$	585		595	nm
Green	PP525-8L63-ESESBI	Dominant Wavelength	$\lambda d$	520		530	nm
Blue	PP465-8L63-ESESBI	Dominant Wavelength	$\lambda d$	460		470	nm
white	PP00W-8L63-ESESBI	Correlated Color Temperature	CCT	4500		10000	K

\* Dominant Wavelength Measurement allowance is ±0.5nm.

9. Color Spectrum Curves

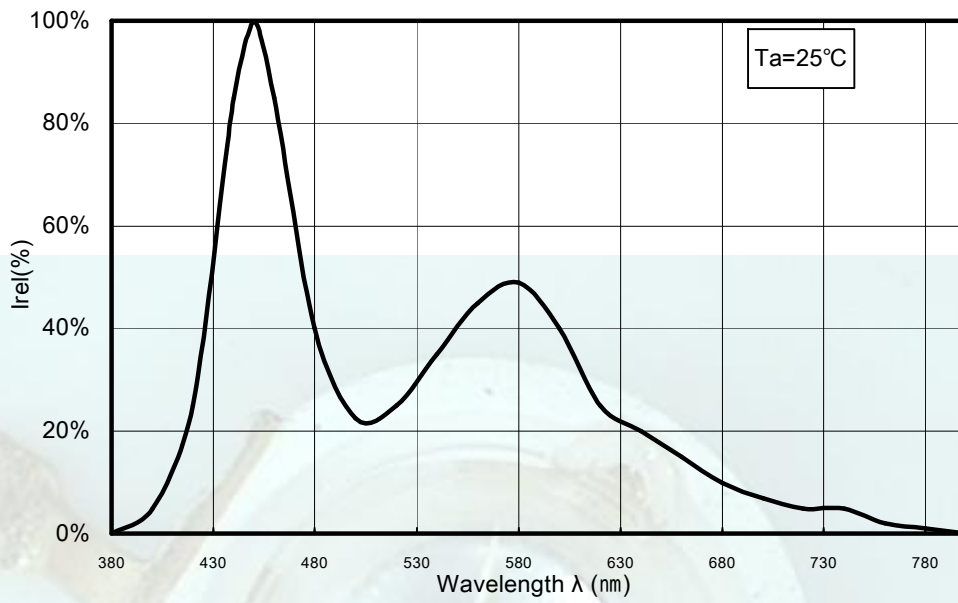

10. Wavelength spectrum.



11. Forward Current & Ambient Temperature.

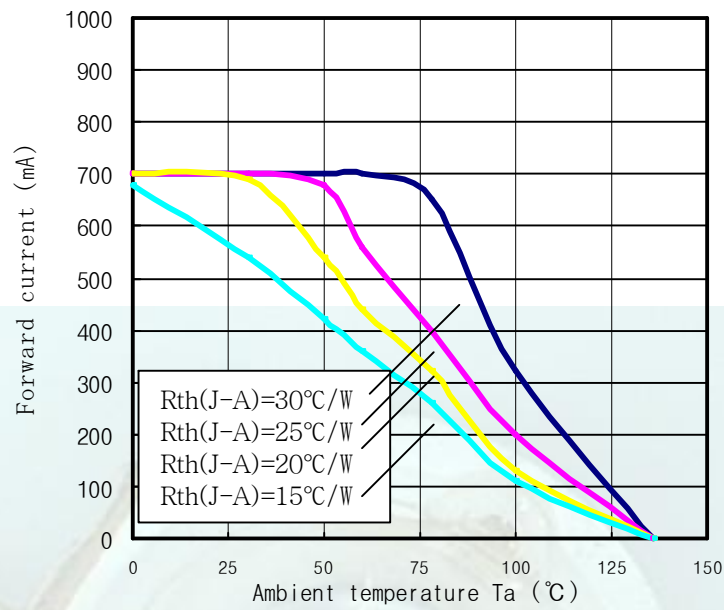

12. Relative Light Output VS Junction Temperature

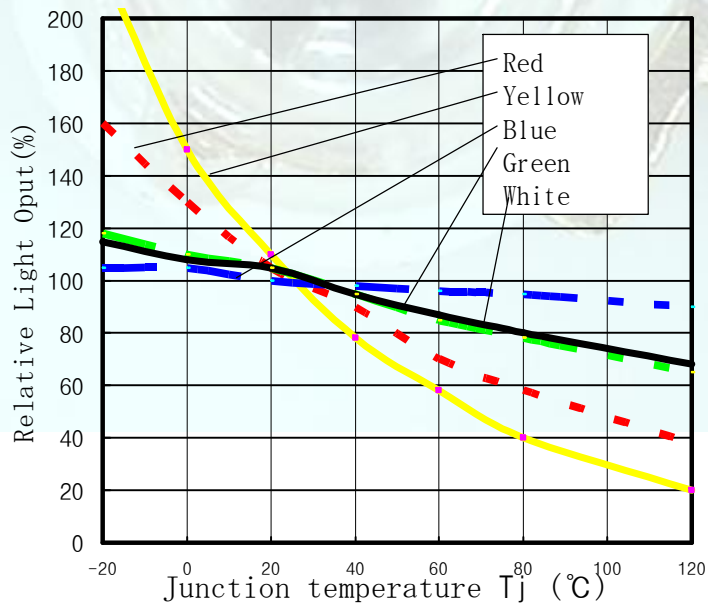

13. Typical Radiation Pattern.

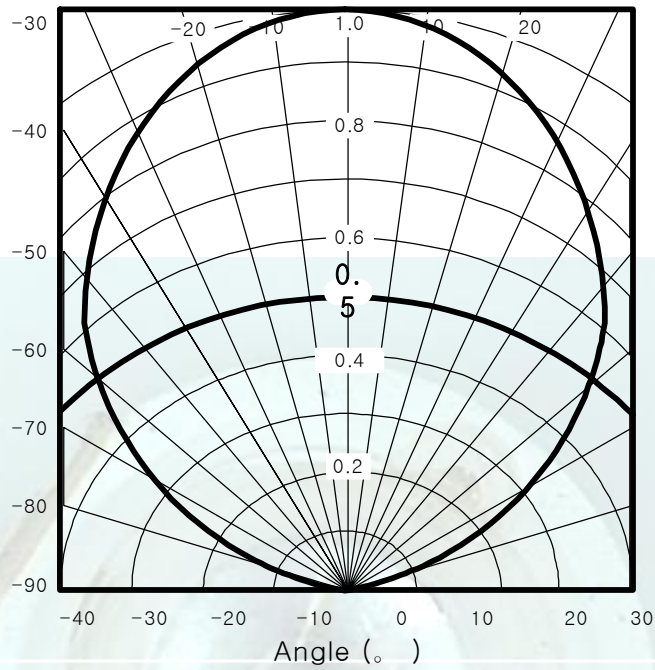

Typical Radiation Pattern (black Collimator).

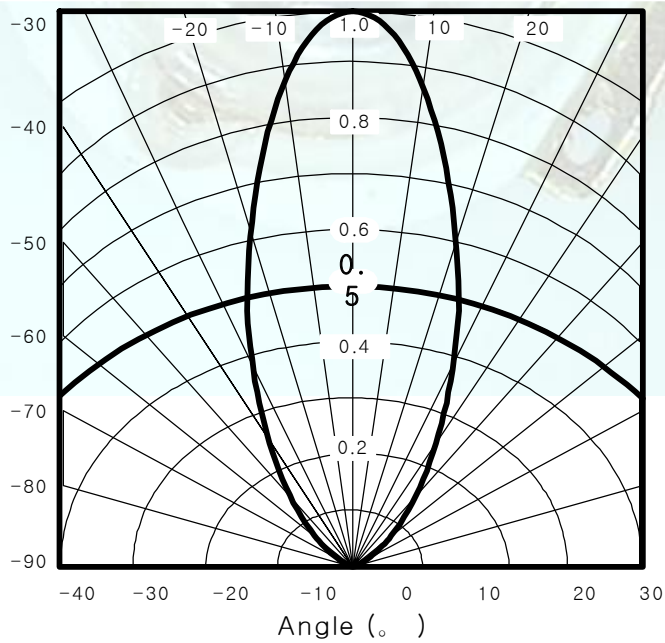

14. Green Forward Current & Ambient Temperature.

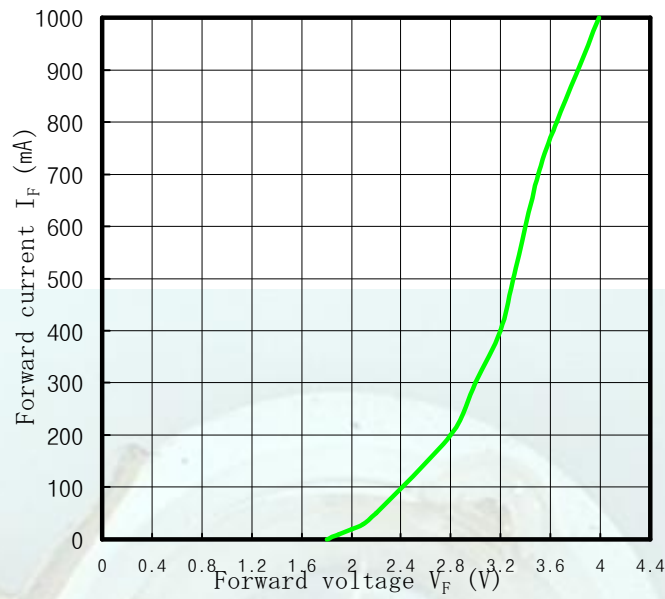

Blue, white Forward Current & Ambient Temperature.

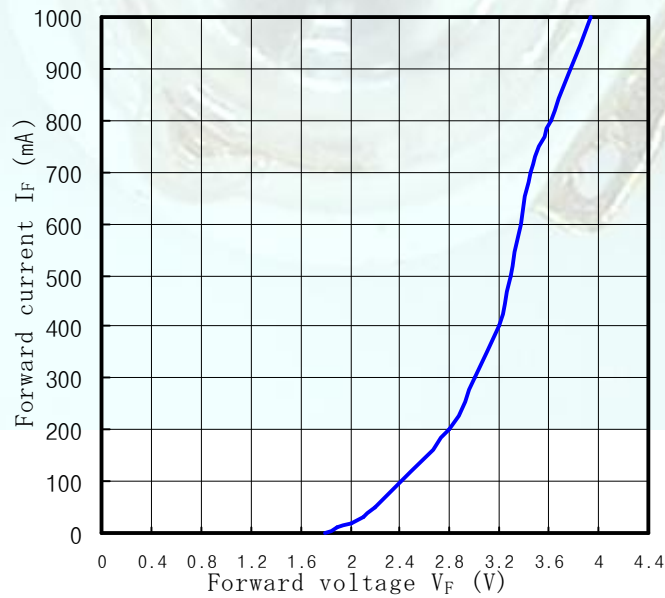

Red Forward Current & Ambient Temperature.

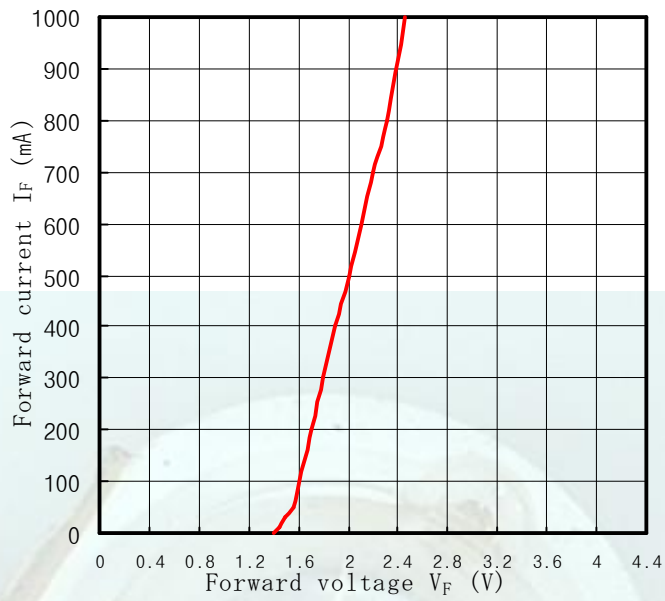

Yellow Forward Current & Ambient Temperature.

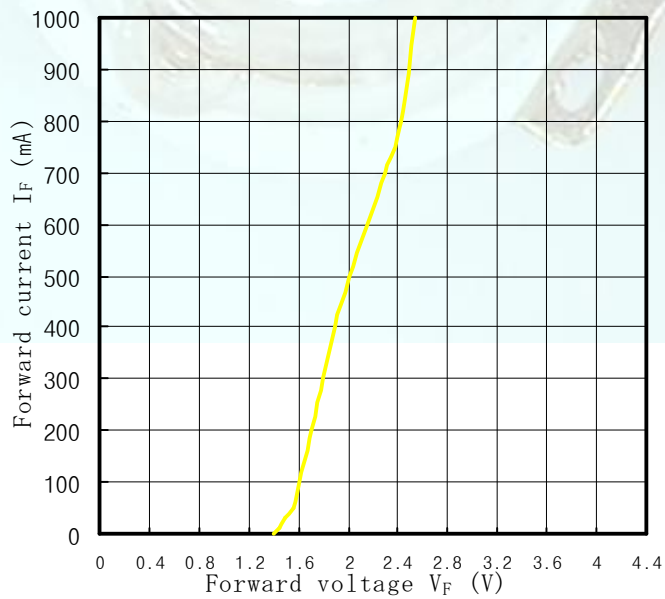

15. Relative Luminous Flux & Forward Current.

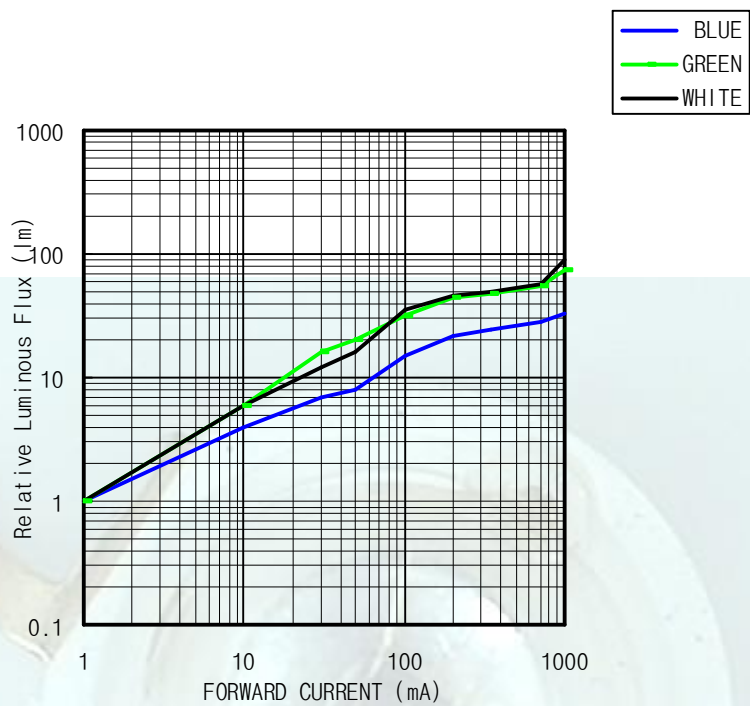

Relative Luminous Flux & Forward Current.

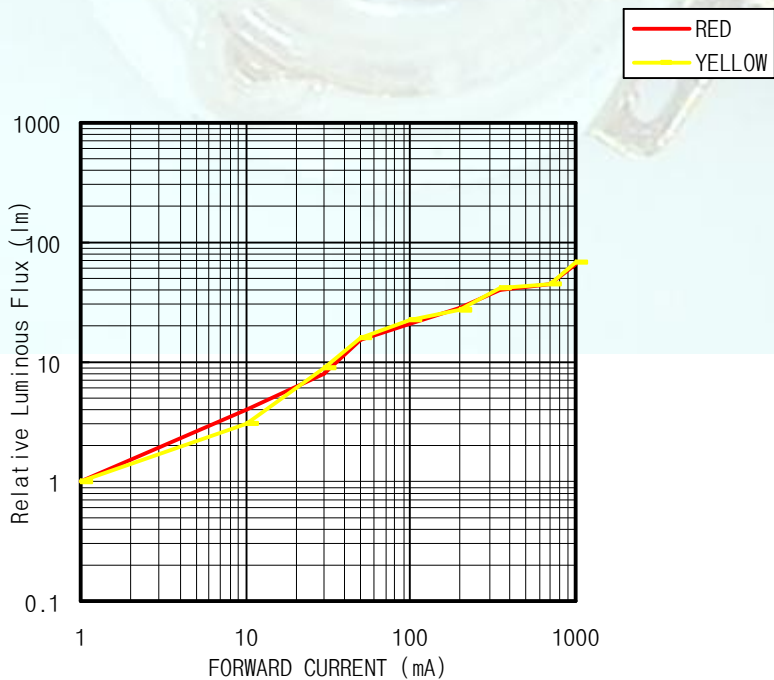

1. Wavelength Rank (If=700mA)

Part no	Rank	min	typ	max	Unit
UV	U1	370		375	
	U2	395		405	
Blue	B1	460		465	
	B2	465		470	
	B3	470		475	
Green	G1	515		520	
	G2	520		525	
	G3	525		530	
	G4	530		535	
Amber	A1	585		588	
	A2	588		591	
	A3	591		594	
Red Orange	R1	610		620	
Red	R2	620		630	
IRED		935		945	
		840		860	

2. Flux Ranks

Part no	Flux Rank	Flux(lm)@If=700mA	Unit
RED YELLOW BLUE GREEN WHITE	A	4.0 – 10	lm
	B	10 – 16	lm
	C	16 – 20	lm
	D	20 - 26	lm
	E	20 - 28	lm
	F	28 - 36	lm
	G	36 - 46	lm
	H	46 - 56	lm
	I	56 - 66	lm
	J	66 - 86	lm
	K	86 - 100	lm
	L	100 - 120	lm
	M	120 - 140	lm

3. Radiant Flux Ranks( $I_f=700\text{mA}$ )

Part no	Rank	Radiant Flux(mW)			Unit
		min	typ	max	
RED YELLOW BLUE GREEN WHITE		50		80	mW
		80		95	mW
		95		115	mW
		115		140	mW
		140		170	mW
		170		205	mW
		205		250	mW
		250		305	mW
		305		400	mW
		400		490	mW
		490		595	mW
		595		725	mW
	725		885	mW	

## 4. Forward Voltage Rank (If=700mA)

Part no	Rank	min	typ	max	Unit
RED YELLOW BLUE GREEN WHITE	V1	1.80		2.00	V
	V2	2.00		2.30	V
	V3	2.30		2.60	V
	V4	2.60		2.90	V
	V5	2.90		3.10	V
	V6	3.10		3.40	V
	V7	3.40		3.70	V
	V8	3.70		4.00	V
	V9	4.00		4.30	V



Color Rank(I<sub>f</sub>=700mA)

Group	Rank					Group	Rank				
UA	X	0.362	0.360	0.344	0.346	WD	X	0.329	0.316	0.315	0.329
	Y	0.372	0.357	0.344	0.359		Y	0.345	0.333	0.344	0.357
UB	X	0.364	0.362	0.346	0.347	WE	X	0.314	0.329	0.329	0.315
	Y	0.385	0.372	0.359	0.372		Y	0.355	0.369	0.357	0.344
UC	X	0.364	0.367	0.348	0.347	XA	X	0.308	0.317	0.319	0.311
	Y	0.385	0.400	0.385	0.372		Y	0.311	0.320	0.300	0.293
VA	X	0.329	0.344	0.343	0.329	XB	X	0.308	0.306	0.316	0.317
	Y	0.331	0.344	0.331	0.320		Y	0.311	0.322	0.333	0.320
VB	X	0.329	0.329	0.346	0.344	XC	X	0.306	0.303	0.315	0.316
	Y	0.331	0.345	0.359	0.344		Y	0.322	0.333	0.344	0.333
VC	X	0.329	0.329	0.347	0.346	XD	X	0.301	0.314	0.315	0.303
	Y	0.345	0.357	0.372	0.359		Y	0.342	0.355	0.344	0.333
VD	X	0.329	0.329	0.348	0.347	YA	X	0.304	0.299	0.308	0.311
	Y	0.357	0.369	0.385	0.372		Y	0.285	0.301	0.311	0.293
WA	X	0.329	0.329	0.319	0.318	YB	X	0.308	0.299	0.292	0.303
	Y	0.321	0.310	0.300	0.310		Y	0.311	0.301	0.321	0.333
WB	X	0.329	0.329	0.318	0.317	YC	X	0.308	0.283	0.274	0.303
	Y	0.331	0.320	0.310	0.320		Y	0.311	0.284	0.301	0.333
WC	X	0.329	0.329	0.317	0.316	YD	X	0.308	0.311	0.290	0.283
	Y	0.345	0.331	0.320	0.333		Y	0.311	0.293	0.270	0.284

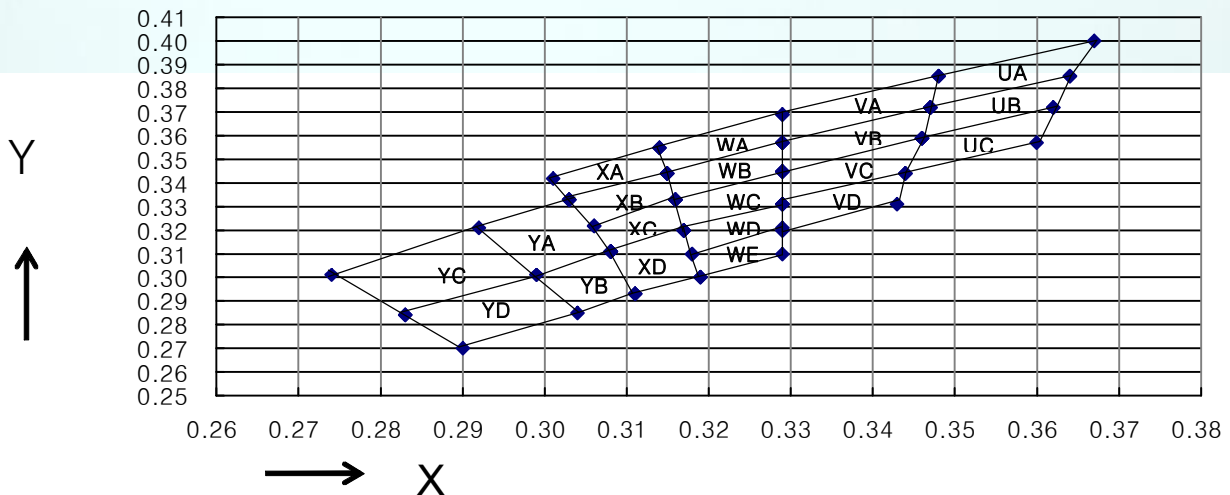

16. Results of Reliability Test

item	Test Condition	Note	Fail / Sample
Temperature cycle	-40℃ 30min ~ 25℃ 5min ~100℃ ~ 25℃30min	100 cycles	0/45
High temperature storage	Ta = 100℃	500 hrs	0/45
Temperature humidity storage	Ta=60℃ RH=90%	500 hrs	0/45
Low temperature storage	Ta = -40℃	500 hrs	0/45
Operating life time	Ta = 25℃ If=350mA	500 hrs	0/45
Solderability	260℃ for 5sec 1time	1time	0/10



## ◆ Soldering conditions

- When soldering leave minimum clearance between the resin and soldering point
- Maximum allowable soldering conditions  
Soldering dipping: 260 degrees C max., 5 seconds max.,  
Soldering iron: 340 degrees C max., 3 seconds max., 1 time 40w max.
- Contact between molten solder and the resin must be avoided.
- In soldering, do not apply any stress to the lead frame, particularly heated.

## ◆ storage

- Storage Conditions

Before opening the package

The LEDs should be kept below 30°C and 70%RH. When storing the LEDs, try to unpack the moisture proof package and store them in a dry place. If the LEDs are stored for 3months or more after being from PHOTRON, a sealed container with a nitrogen atmosphere is recommended for storing.

After opening the package

The LEDs should be kept below 30°C and 70%RH. The LEDs should be soldered within 24hours after opening the package. If there is leftover, they should be stored in moisture proof package with moisture absorbent material(e.g. silica gel) inside.

- It is strongly recommended that the user use the LEDs as soon as possible since there exist a possibility that unfavorable environmental factors could deteriorate the properties of the LEDs.

## ◆ Static Electricity

- Static electricity or surge voltage damages the LEDs.

It is recommended that a wrist bond or an anti-electrostatic glove be used when handling the LEDs.

- All devices, equipment and machinery must be properly grounded.

It is recommended that measures be taken against surge voltage to the equipment that mounts the LEDs.

- When inspecting the final products in which LEDs were assembled, it is recommended to check whether the assembled LEDs are damaged by static electricity or not. It is easy to find static-damaged LEDs by a light-on test or a VF test at a lower current (below 1mA is recommended).
- Damaged LEDs will show some unusual characteristics such as the forward voltage becomes lower. Or the LEDs do not light at the low current.

-

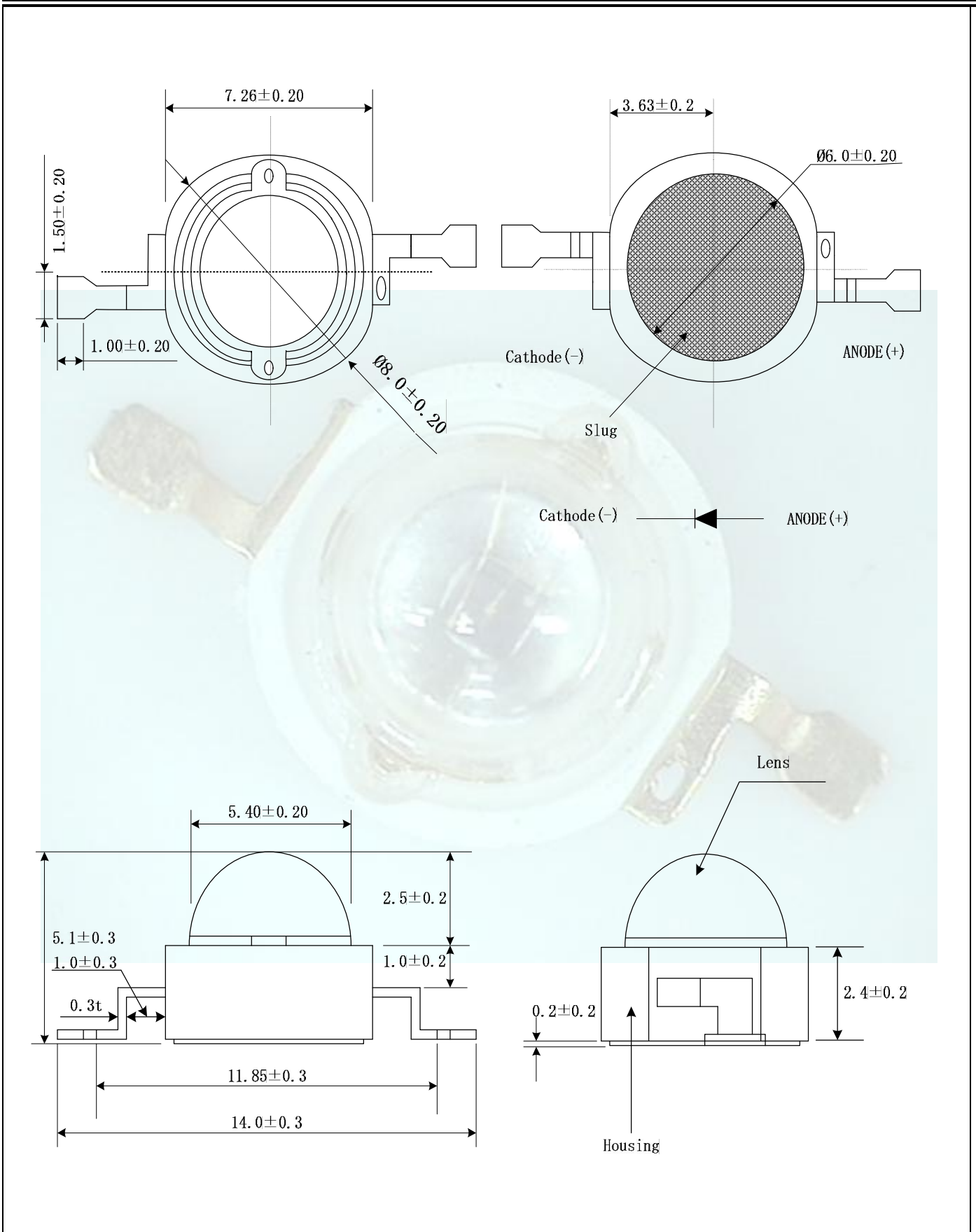

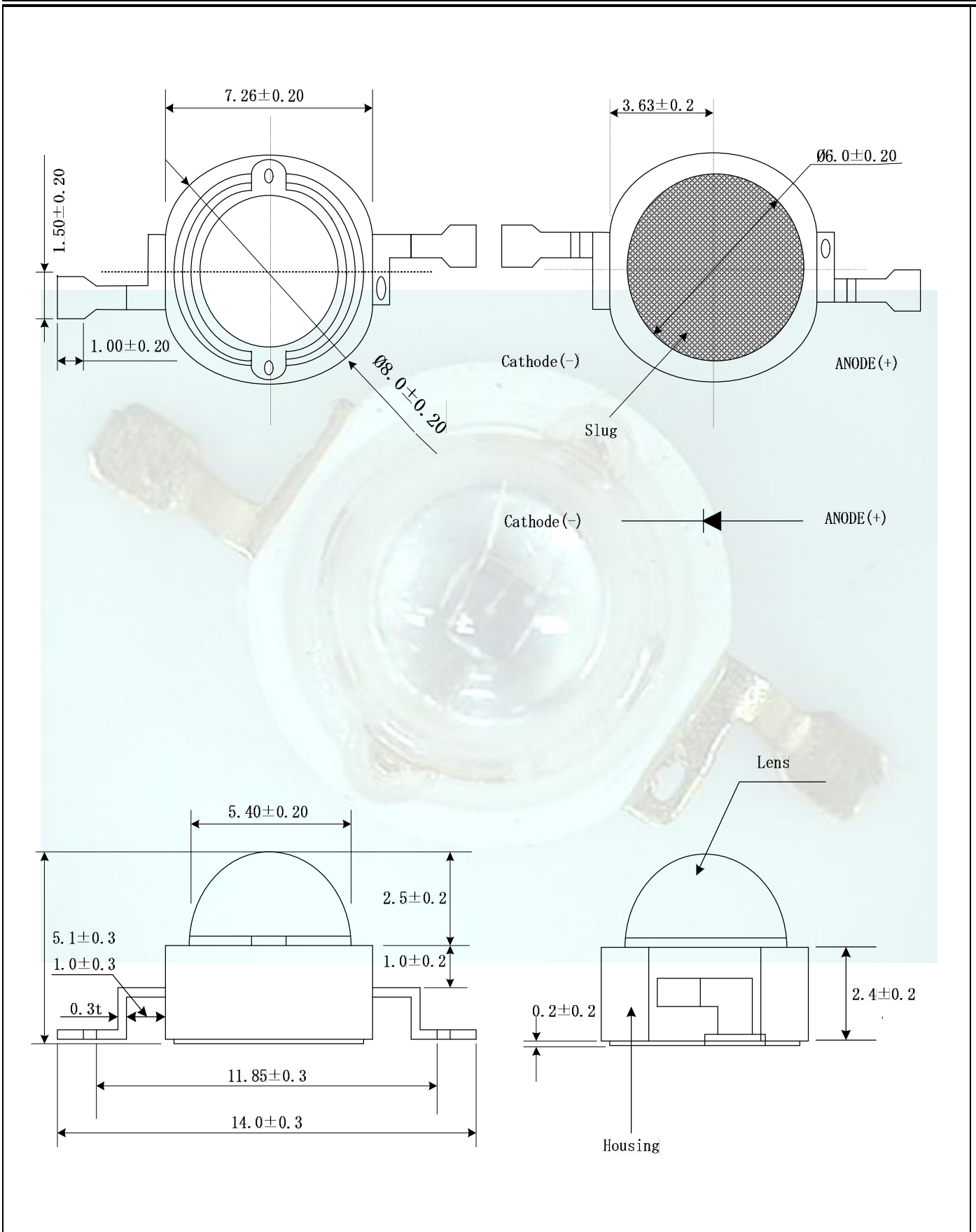

개정	변경 전	변경 후	변경사유	적용 일자	Page
	품명/규격	품명/규격			
1.0	R,G,B,A POWER		임시사양 제정	2007-06-14	22

